

# Advanced Dissolved Oxygen Meter

with Optical and Polarographic Probe Compatibility



HI6421 and HI6421P are streamlined benchtop meters with a large touch screen display, comprised of a housing and an integrated module designed for fresh and saltwater measurements of dissolved oxygen.

HI6421 includes Hanna's HI7641133 optical dissolved oxygen probe (opdo®) that is based on the principle of fluorescence quenching. An immobilized Pt-based luminophore is excited by the light of a blue LED and emits a red light. As oxygen interacts with the luminophore it reduces the intensity and lifetime of the luminescence. The lifetime of the luminescence is measured by a photodetector and is used to calculate the dissolved oxygen concentration.

The probe is fitted with easy to use Smart Caps (HI764113-1) which lock in place and contain pre-loaded calibration coefficients that are automatically transmitted to the probe. The Smart Cap features an immobilized O<sub>2</sub> sensitive luminophore with rugged insoluble black oxygen permeable protective layer.

Over time, the sensor's optical components can age but are compensated for by using the reference signal to compensate the measuring path. As a result, the sensor provides accurate DO measurements over long periods of time without the need for frequent calibration.

HI6421P includes the HI764833 polarographic probe. Slim and versatile, this probe covers a wide range of dissolved oxygen and has a built-in

thermistor temperature sensor that compensates for temperature variations. The slim design allows for convenient measurement in test tubes and Biological Oxygen Demand (BOD) bottles.

Durable and robust, the probe features a platinum cathode and Ag/AgCl anode assembly. Accurate and with a fast response time, readings are not flow dependent.

The probe is fitted with durable (PTFE), oxygen permeable, screw on membrane caps. Caps are filled with electrolyte and easily installed on the probe.

Concentration measurements are automatically compensated for barometric pressure, temperature, and salinity. Barometric pressure and temperature are automatically measured and compensated. Salinity is automatically compensated by setting manually the salinity concentration of the water being measured.

Additional features include built-in methods and calculations for the measurement of BOD (Biological Oxygen Demand), OUR (Oxygen Uptake Rate), and SOUR (Specific Oxygen Update Rate).

Pressure compensation is done automatically (built-in barometer) or users have the option to manually enter required value. Pressure is displayed in user-configurable units: mmHg, mbar, kPa, inHg, psi, atm.

## User interface

- 7-inch capacitive touch screen with multi-touch support
- Capacitive touch back, home and system menu keys
- User-friendly icons and symbols allow users to easily navigate and interpret the instrument functions.
- The user can select between five different views:
  - Basic measurement configuration
  - Simple GLP with calibration information
  - Full GLP with electrode status and calibration point details
  - Live updated, interactive graph
  - Tabulated data with date, time, and notes

## Measurement

- Measure %Sat, mg/L, ppm (DO); mg/L, ppm (BOD); mg/L (OUR); ppm, mg/L (SOUR)
- Application-specific profiles allow quick and direct measurement without the need to update the sensor and system settings

- Active log during measurement
- Measurement stability indicator (using the Stability Criteria setting)
- Reading modes: direct and direct/autohold
- Temperature compensation can be Automatic or set manually
- Audible and/or alarm messages for measurements outside of predefined limits
- Galvanic isolation for measurement

## Calibration

- One or two points calibration at 0% and/or 100% saturation
- Single point manual calibration in mg/L or % saturation using a reference method
- Non-volatile memory saves data and settings

## Logging

- Data log collection of at least 1,000,000 data points (with time and date stamp)

- Logging types: manual, automatic, autohold
- Sample ID for manual and Autohold data

## Connectivity features & services

- Transfer logged data to a USB thumb drive
- Log files that include measurements and calibration data (as .csv file)
- FTP and email for log export via Ethernet and Wi-Fi connection
- USB type A for USB stick, keyboard, and printer
- USB type C for USB stick and PC connection

## Help section for meter guidance

- Video support presentation of main functionalities



This system responds to a complex range of measurement and monitoring requirements, providing accuracy, reproducibility, and reliability.

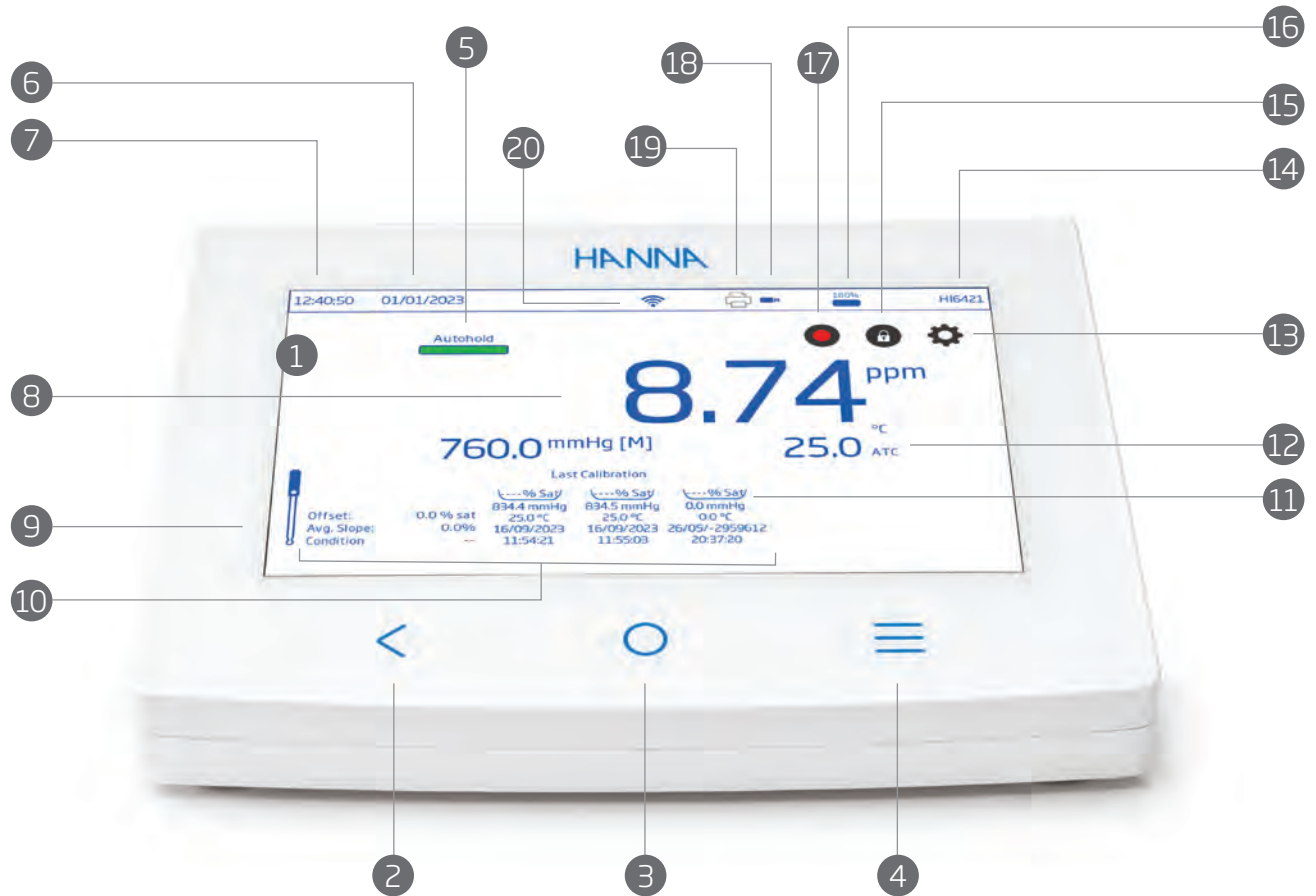

### 1. Capacitive touch screen with multi-touch support

The benchtop unit has a 7-inch color display with 800 x 480p resolution. The capacitive, multi-touch screen supports video playback and data plotting.

### 2. Back key

### 3. Home key

### 4. System Menu key

This key will enter the system menu where User accounts, System Settings, and Logging can be configured. The Help menu is also accessed on the system menu screen.

### 5. Stability indicator

### 6. Current date

### 7. Current time

### 8. Main reading

### 9. Probe icon

### 10. Calibration information: Electrode condition, Offset, Slope, Date and Time

### 11. Buffer trays

### 12. Temp. reading

### 13. Measurement setup menu

Opens sensor setup parameters.

### 14. User name (default shown)

### 15. Direct/Autohold Readings

When Direct/Autohold is selected, measurement reading is held on display when measurement stability is reached. This option removes the subjective nature of stability as a measurement that has not reached equilibrium will not be used.

When not selected, sample measurements are displayed continuously.

### 16. Logging space availability

### 17. Logging start

### 18. USB connection status

### 19. Peripheral connection status

### 20. Wireless network connection status

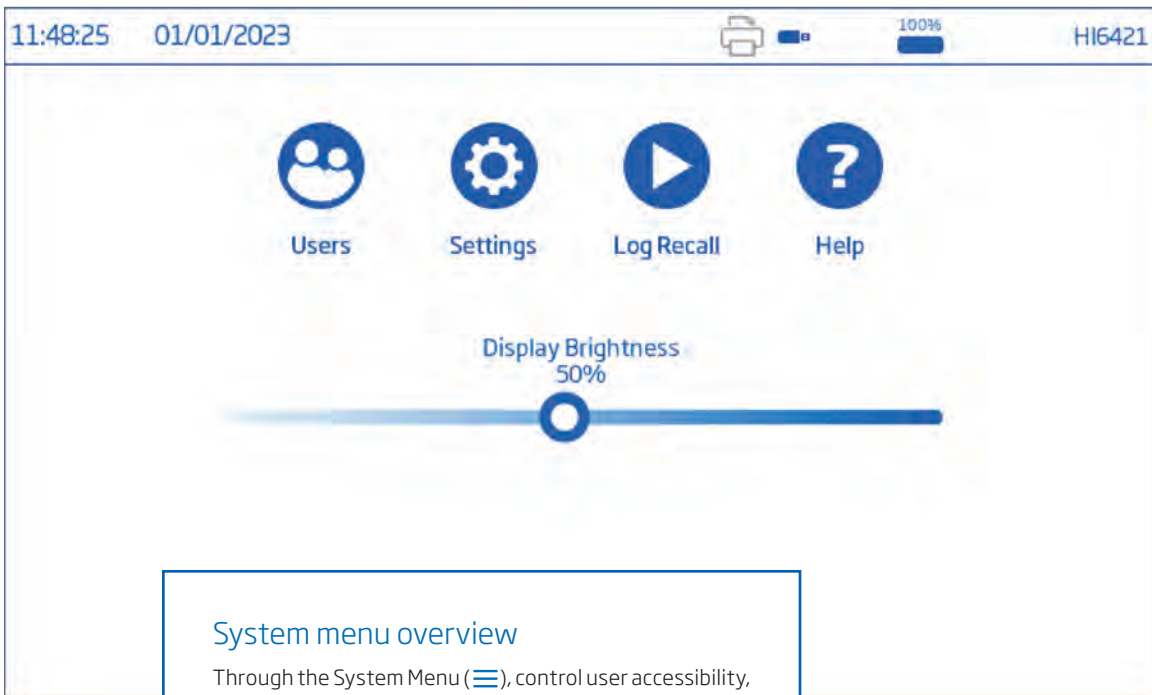

**System menu overview**

Through the System Menu (☰), control user accessibility, system and connectivity configuration, access logged data and video-supported help.

- Add and delete user accounts through Users (👤).
- Access Network Connectivity, System and Info tabs through Settings (⚙️).
- Log Recall (▶️) recalls stored log sessions (Automatic continuous logging, Manual, or Autohold).
- Help (❓) guides users with video-supported help.





## Users



### Custom Users

New administrator or standard user accounts can be created. Standard accounts can be configured for specific accessibility.

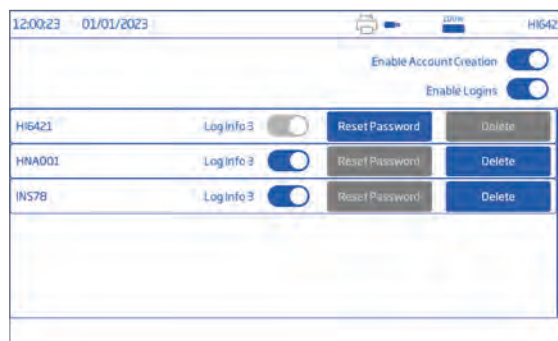

### User Account Management

Administrators can create and manage accounts from the Account Management Screen.



## Settings

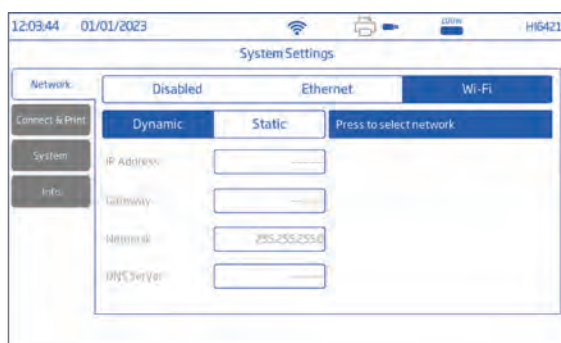

### Network Screen

Determine how measurement logs are shared through network settings. Users can select network to be connected via Ethernet or Wi-Fi, or Disabled.

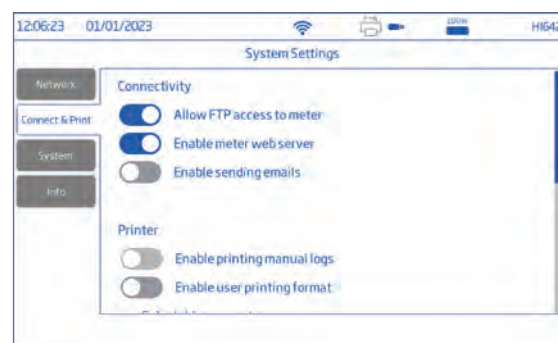

### Connect and Print Screen

Activate connectivity options to allow the meter to connect to other devices.

- FTP access to meter, permits log file transfer to a FTP site and to connect the meter FTP server to a client for log download.
- Meter web server, permits log file download to a web client.
- Sending emails, permits log files to be transferred by email.



### System Screen

The system screen enables users to configure options such as: Time, Date, Language, Meter ID, Decimal Separator, Backlight Saver, Audible signals, Startup Tutorial, and Factory Settings restore.



### Info Screen

Displays information on meter, channel serial number, and Wi-Fi firmware version.



## Log Recall

Name	Parameter	Start/Stop	Share To
20220916_121743-DO_auto.csv	Dissolved Oxygen	12:17:43 16/09/2022 12:18:06 16/09/2022	USB A
20220916_121809-DO_auto.csv	Dissolved Oxygen	12:18:10 16/09/2022 12:18:41 16/09/2022	Cancel
20220916_121901-DO_auto.csv	Dissolved Oxygen	12:19:01 16/09/2022 12:19:44 16/09/2022	44
20220916_122000-DO_auto.csv	Dissolved Oxygen	12:20:00 16/09/2022 12:20:46 16/09/2022	39
20220916_122546-DO_auto.csv	Dissolved Oxygen	12:25:46 16/09/2022 12:26:14 16/09/2022	29
20220916_123021-DO_auto.csv	Dissolved Oxygen	12:30:21 16/09/2022 12:31:07 16/09/2022	47
		12:32:22 16/09/2022	

## Log History and Sharing

The item allows users access and management (selection, deletion, and sharing) of measurement data. Only the user who generated the data has access to the logs created by that user.

Data can be viewed tabulated (complete with date, time, and notes), or plotted (as graph).

Log files can be shared via USB, FTP, web server and email.

Sample ID	Date	Time	% Sat	mmHg	Notes
7	16/12/2022	12:17:43	0.000	0.0	X "Factory calibration expire [more]
7	16/12/2022	12:17:44	0.000	0.0	X "Factory calibration expire [more]
7	16/12/2022	12:17:45	0.000	0.0	X "Factory calibration expire [more]
7	16/12/2022	12:17:46	0.000	0.0	X "Factory calibration expire [more]
7	16/12/2022	12:17:47	0.000	0.0	X "Factory calibration expire [more]
7	16/12/2022	12:17:48	0.000	0.0	X "Factory calibration expire [more]
7	16/12/2022	12:17:49	0.000	0.0	X "Factory calibration expire [more]
7	16/12/2022	12:17:50	0.000	0.0	X "Factory calibration expire [more]
7	16/12/2022	12:17:51	0.000	0.0	X "Factory calibration expire [more]
7	16/12/2022	12:17:52	0.000	0.0	X "Factory calibration expire [more]

## Table View

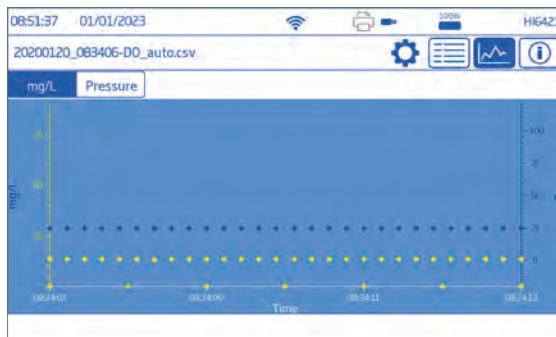

## Graph View

**20220920\_072558-DO\_auto.csv**

**INSTRUMENT INFO**  
 Instrument Name: HI6421-ID1  
 ID: HI6421  
 Serial Number: 123456789QRS  
 Firmware Version: 0.1.220916-RO1

**INTERFACE INFO**  
 Module Type: DO  
 Module Serial Number: 000031  
 Module Firmware: 4.1.1

**GLP DATA**  
 Calibration point: 3.0%

Date/Time: 16/09/2022 11:54:21

## Log Detail

Tapping the information icon displays log details such as user and profile name, instrument name and serial number, channel, lot information, as well as GLP data.



## Help

**Hanna Tutorial System**

- 1. HI6221 First Look
- 2. Getting Started
  - 2.1. Get familiar with functionalities
  - 2.2. Users
  - 2.3. Meter settings
  - 2.4. Setting measurement
- 3. General Operations
- 4. General Operations
- 5. Troubleshooting guide
- 6. Accessories and Warranty

**2.1. Get familiar with functionalities**  
**Screens explained**  
**Main View** - This screen shows the current measurement according to the measurement settings and give access to the user calibration and measurement settings options.

**Main Menu** - This screen gives the user access to the 5 main icons

## On-board Help

The HELP menu supports users with a brief overview of the system's main functionalities through text and video tutorials.

**Hanna Tutorial System**

- 1. HI6221 First Look
- 2. Getting Started
  - 2.1. Get familiar with functionalities
  - 2.2. Users
  - 2.3. Meter settings
  - 2.4. Setting measurement
- 3. General Operations
- 4. General Operations
- 5. Troubleshooting guide
- 6. Accessories and Warranty

**2.4. Setting up measurement**  
 Your measurement screen can be configured by pressing **Q**.

**Channel Settings**

**READING**

Mode: pH, mV, Rel. mV



## Measurement Setup Configuration

12:46:02 01/01/2023 H16421

Channel Settings

Calibration: Stability Criteria: **Accurate** Medium Fast

Reading: Parameter: **DO** BOD<sub>5</sub> OUR SOUR

Temperature: Units: **% Sat** mg/L ppm

View: Pressure Source: **Automatic** Manual

Alarm: Pressure: 760.0

Logging: Pressure Unit: **mmHg** mbar kPa

Profiles:

### Reading

Customize measurement options such as Stability Criteria, Parameter, Units, Pressure Source, Pressure Unit.

12:47:26 01/01/2023 H16421

Channel Settings

Calibration: Temperature Source: **Manual** MOD1 Manual

Reading: Temperature Unit: **°C** °F K

View: Manual: 25.0 °C

Alarm: Last Calibration: **Calibrate** Clear

Logging: Profiles:

### Temperature

Customize temperature options such as Automatic or manual temperature Source, °C, °F, or K temperature Unit, Manual Temperature input, or clear last temperature calibration.

12:44:40 01/01/2023 H16421

Channel Settings

Calibration: Last Calibration: **Calibrate** Clear

Reading: Calibration Type: **Automatic** Manual

Temperature: Calibration Remider: **Disabled** Daily Periodic

View: Min: Max: Days: Mon: Tues: Wed: Thurs: Fri: Sat: Sun

Alarm: Logging: Profiles:

### Calibration

Customize calibration options such as Last Calibration, Automatic or Manual calibration, and Daily or Periodic Calibration Remider

12:51:19 01/01/2023 H16421

Channel Settings

Calibration: High DO:  0.0 % Sat

Reading: Low DO:  0.0 % Sat

Temperature: High Pressure:  800.0 mmHg

View: Low Pressure:  460.0 mmHg

Alarm: High Temperature:  50.0 °C

Logging: Low Temperature:  10.0 °C

Profiles:

### Alarm

Alarm configuration allows users to set the high and low threshold limits for the measured parameters. When the parameter is enabled and the the measurement exceeds the high-limit value or drops below the low-limit value, the alarm is triggered and will appear on the message banner along with an audible alarm (if Alarm Beepers is enabled).

12:52:51 01/01/2023 H16421

Channel Settings

Calibration: Log Info 1:

Reading: Log Info 2:

Temperature: Log Info 3:

View: Log Info 4:

Alarm: Sample ID: **None** Increment Manual

Logging: Sample ID Prefix:

Profiles:

### Logging

Logging Type (automatic, manual or autohold), Sampling Period (Automatic), Logging Resolution, File Name (with Manual type selected), Log Note and Info, Sample ID (Increment or Manual) can be configured under this option menu.

12:55:08 01/01/2023 H16421

Channel Settings

Calibration: Current Profile: **Chem-Lab-04**

Reading: **Save As** Save Delete

Temperature: Load Profile: **Chem-Lab-04**

View: Alarm: Logging: Profiles:

### Profiles

A profile is a sensor setup complete with required measurement unit, temperature unit, display preference, and alarm threshold options.

Once saved the profile can be loaded for applications that require similar configurations.

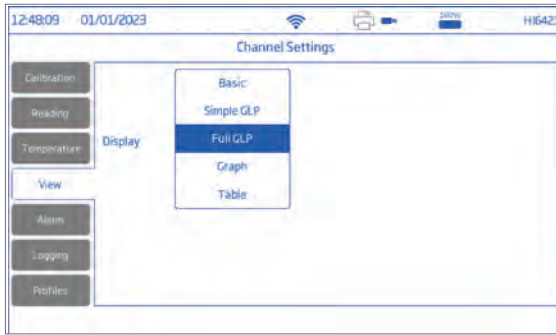

### View Configuration

This screen allows users to select the preferred display configuration. Option to select between: Basic, Simple GLP, Full GLP, Graph, Table.



### Basic View

Basic screen displays the measured value, measurement unit as well as temperature source.



### Simple GLP View

In addition to data displayed when Basic option is selected, screen also displays: last calibration date and time and offset value.



### Full GLP View

In addition to data displayed when Simple GLP option is selected, screen also displays: electrode symbol, used buffers trays together with calibration date and time.



### Graph View

When Graph is selected, the measured value is plotted as a graph.



### Table

When Table is selected, the measured values are displayed tabulated (complete with date, time, and notes made during logging). The newest data is displayed on the top of the table.

## Electrode Holder

HI6421 and HI6421P is supplied with an electrode holder featuring a flexible arm. The holder can be mounted on either side quickly and provides secure support for electrodes while taking measurements in sample containers.



## Rear Ports

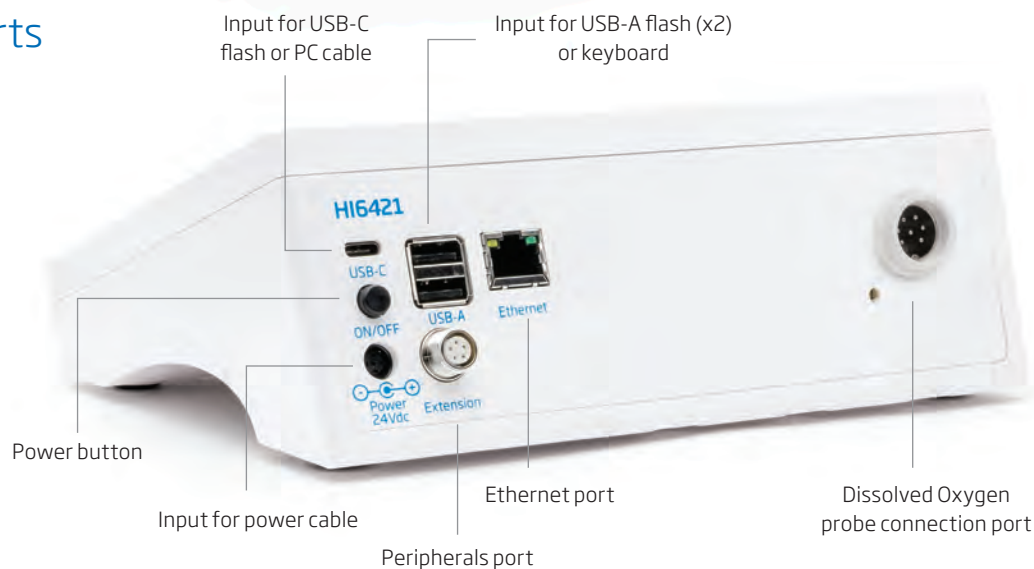

### Specifications

#### HI6421 • HI6421P

DO (HI7641133 Optical probe)	Range	0.00 to 50.00 mg/L (ppm) concentration; 0.0 to 500.0 % saturation
	Resolution	0.01 mg/L (ppm); 0.1 % saturation
	Accuracy	from 0.00 to 20.00 mg/L (ppm) 1.5 % of reading or $\pm 0.01$ mg/L (ppm), whichever is greater from 20.00 to 50.00 mg/L (ppm) $\pm 5$ % of reading from 0.0 to 200.0 % saturation $\pm 1.5$ % of reading or $\pm 0.1$ %, whichever is greater from 200.0 to 500.0 % saturation $\pm 5$ % of reading
DO (HI764833 Polarographic probe)	Range	0.00 to 90.00 mg/L (ppm) concentration; 0.0 to 600.0 % saturation
	Resolution	0.01 mg/L (ppm); 0.1 % saturation
	Accuracy	$\pm 1.5$ % of reading $\pm 1$ , least significant digit

Barometric Pressure	Range	450 to 850 mmHg; 600 to 1133 mBar; 60 to 133 kPa; 17 to 33 inHg; 8.7 to 16.4 psi; 0.592 to 1.118 atm
	Resolution	1 mmHg; 1 mBar; 1 kPa; 1 inHg; 0.1 psi; 0.001 atm
	Accuracy	±3 mmHg within ±15 % from the calibration point ±3 mmHg ±1 least significant digit
Temperature	Range	-20.0 to 120.0 °C -4.0 to 248.0 °F 253.0 to 393.0 K
	Resolution	0.1 °C; 0.1 °F; 0.1 K
	Accuracy	±0.2 °C; ±0.4 °F; ±0.2 K
DO Calibration	Points	DO optical One or two points automatic calibration at 100% (8.26 mg/L) and 0% (0 mg/L). Single point manual using a value entered by the user in % saturation or mg/L. DO polarographic Automatic-two points / User standard-single point
	Standards	0 and 100% saturation
	Reminder	Disabled Daily: 0 min. to 23 hours and 59 min. Periodic: 1 min. to 500 days, 23 hours and 59 min.
Temperature Compensation		Automatic or Manual
Salinity Compensation (Optical DO only)		Automatic from 0 to 70 PSU (manually set) 0.0 to 70.0 % / 0.0 to 45.0 g/L / 0.0 to 42.0 psu
Reading	Modes	Direct Direct/Autohold
	Stability criteria	Accurate Medium Fast
	Isopotential	7.000 or 4.010
	Sampling rate	1000 ms
DO Views	Basic	Measurement (DO, Temperature) Stability status
	Simple GLP	Basic view information Last calibration date, offset, average slope
	Full GLP	Simple GLP information and calibration point details
	Table	Measurements updated every second are displayed in table
	Graph (Plot)	Measurement versus time graph can be panned or zoomed (pinch-to-zoom technology)
Logging	Type	Automatic, Manual, Autohold
	Number of records	50 000 maximum per file Stores at least 1 000 000 data points per user
	Automatic interval	1, 2, 5, 10, 30 seconds 1, 2, 5, 10, 15, 30, 60, 120, 150, 180 minutes
	Sample ID	Incremental mode
Export option		.csv file format
Users		Up to 9 users and the default administrator account
Connectivity	USB-A	2 ports for keyboard input or USB thumb drive
	USB-C	1 port for PC connectivity and USB-C type thumb drive
	Wi-Fi & Ethernet	FTP Web server Log transfer and download Email
	RS232	Connecting peripherals
Power supply		DC adapter 100-240AC to 24VDC 2.5A
Environment		0 - 50 °C / 32 - 122 °F / 273 - 323 K maximum 95% RH non-condensing
Dimensions		205 x 160 x 77 mm (8.0 x 6.2 x 3.0")
Weight		Approximately 1.2 kg (26.5 lbs.)
Ordering Information	<b>HI6421</b> is supplied with HI7641133 optical dissolved oxygen probe (opdo®); HI764060 electrode holder; capillary pipette; 24 VDC power adapter; USB-C to USB-A cable; probe quality certificate; quick reference guide with instrument quality certificate.	
	<b>HI6421P</b> is supplied with HI764833 polarographic probe; HI764060 electrode holder; capillary pipette; 24 VDC power adapter; USB-C to USB-A cable; probe quality certificate; quick reference guide with instrument quality certificate.	