



Technology for Vacuum Systems

Instructions for use



DCP 3000

Vacuum gauge



LAB Online Exhibition



Dear customer,

Your VACUUBRAND vacuum gauges should support you for many years without trouble and with optimal performance. Thanks to our long practical experience we have much information and advice on how you can achieve powerful application usage and personal safety through our products. Please read these instructions for use before the initial operation of your device. VACUUBRAND vacuum gauges are the result of many years of experience in design and construction and practical operation of these gauges combined with the latest developments in material and manufacturing technology.

Our quality maxim is the „zero fault principle“: Every vacuum gauge leaving our company, is tested intensively including an endurance run. Therefore faults, even those which occur rarely, are identified and can be eliminated immediately. The achievement of the specifications after the endurance run is tested for every device.

Every VACUUBRAND device achieves the specifications.

We are committed to providing our customers with this high quality standard.

We know that the device cannot replace all of your real work and hope that our products contribute to an effective and trouble-free realisation of your work.

Yours VACUUBRAND GMBH + CO KG

After sales service: Contact your local dealer or call (++49) 9342/808-193.



Contents

Safety information	4
General information	4
Intended use	4
Connecting the device	4
Ambient conditions	5
Operating conditions	5
Safety during operation	5
Maintenance and repair	6
Technical data	7
Technical data of display equipment	7
Technical data of pressure transducer	7
Wetted parts VSK 3000	8
Technical data of power supply	8
Accessories	8
Use and operation	9
Assembling the country specific mains plug	9
Display and symbols	9
Changing the vacuum connector	11
Notes on operation	11
Menu	12
Configuration	13
Setting of the interface	14
Interface parameters	14
Read commands	15
Write commands	16
Troubleshooting	17
Cleaning the pressure transducer	18
Calibration in the factory	18
Readjustment	19
Notes on return to the factory	20
Health and safety clearance form	21



➔ Danger! Immediate danger. Death or severe injuries as well as damage to equipment and environment can occur.



⚠ Warning! Possible danger. Severe injuries as well as damage to equipment and environment can occur.



• Caution! Possible danger. Slight injuries as well as damage to equipment and environment can occur.



Note. Disregarding of notes may cause damage to the product.



Isolate equipment from mains before removing the cover.

Safety information

General information

NOTICE

Read and comply with this manual before installing or operating the equipment.

Remove all packing material, remove the product from its packing-box, remove the protective covers and keep, inspect the equipment.

If the equipment is damaged, notify the supplier and the carrier in writing within three days; state the item number of the product together with the order number and the supplier's invoice number. Retain all packing material for inspection.

Do not use the equipment if it is damaged.

If the equipment is not used immediately, replace the protective covers. Store the equipment in suitable conditions.

Intended use

WARNING

- ☞ Operate the device only in combination with VACUUBRAND genuine accessories. Make sure that the individual components are only connected, combined and operated according to their design and as indicated in the instructions for use.
- ☞ Comply with notes on correct vacuum and electrical connections, see section "Use and operation".

CAUTION

- The device is designed for ambient and gas temperatures at the pressure transducer connection of +10°C to +40°C at continuous operation. If installing the device into a cabinet or a housing check maximum temperature. Ensure that the maximum permitted gas temperature at the pressure transducer (see "Technical data") is not exceeded.

NOTICE

Use the equipment for the intended use only, i.e. for measurement and control of vacuum.

Connecting the device

WARNING

- ☞ **Avoid uncontrolled overpressure** (e. g. when connecting to a locked or blocked tubing system). **Risk of bursting.**

CAUTION

- **Comply with max. permitted pressure** at the pressure transducer, see section "Technical data".
- Connect hoses at the pressure transducer gas tight.
- The device is equipped with a **short circuit proof wide range power supply** with an integrated overload protection.
- Check that mains voltage and current conform with the equipment (see rating plate)
- Prior to using the wall power supply, assemble and lock the suitable mains plug (included in delivery) to the power supply.
- Comply with **max. permitted ambient and gas temperature** and make sure ventilation is adequate if the equipment is installed in a housing or if ambient temperature is elevated.
- Avoid high heat supply (e. g. due to hot process gases).
- In case of residues or aggressive or condensable media install a gas washing bottle if necessary.

NOTICE

Position the device and its vacuum connection lines so that condensate cannot flow towards the pressure transducer.

Use inert gas for venting if necessary.

Ensure stability of the hose connection. Comply with all relevant **safety requirements.**

NOTICE

When the device is brought from cold environment into a warm room for operation **bedewing** may occur. Allow the device to acclimatise.

Comply with **national safety regulations and safety requirements** concerning the use of vacuum and electrical equipment. comply with all **applicable and relevant safety requirements** (regulations and guidelines), **implement the required actions and adopt suitable safety measures**.

Ambient conditions

NOTICE

To the best of our knowledge the equipment is in compliance with the requirements of the applicable **EC-directives** and harmonized standards with regard to design, type and model, especially directive IEC 1010 (DIN EN 61010.1). This directive gives in detail conditions under which the equipment can be operated safely (see also IP degree of protection).

Adopt suitable measures in case of differences, like using the equipment outdoors, installation in altitudes of more than 1000 m above mean sea level, conductive pollution or dewiness.

Operating conditions

DANGER

➡ **The device has no approval for operation with or in explosive atmospheres.**

NOTICE

Ensure that the materials of the wetted parts are compatible with the substances in the vacuum system, see section “Technical data”.

Safety during operation

DANGER

➡ Adopt suitable measures to prevent the release of dangerous, explosive, corrosive or polluting fluids, gases or vapours.

➡ Prevent any part of the human body from coming in contact with the vacuum.

WARNING

⚠ **Attention:** If the pressure is higher than approximately 1080 mbar the pressure reading becomes incorrect (saturation of the pressure transducer). The display flashes.

Immediate pressure relief necessary! Risk of bursting!

CAUTION

• Use only **genuine spare parts and accessories**. Otherwise safety and performance of the equipment as well as the electromagnetic compatibility of the equipment might be reduced.

Possibly the CE mark or the C/US conformity (see rating plate) becomes void if not using genuine spare parts.

NOTICE

Electronic equipment is never 100% fail-safe. This may lead to an ill-defined status of the equipment or of other connected devices. Provide protective measures against malfunction and failure. Ensure that in case of failure the device and the vacuum system always will turn into a safe status.

Maintenance and repair



Before starting maintenance isolate the device from the electrical supply. **Wait two minutes** after isolating the equipment from mains to allow the capacitors to discharge.

CAUTION

- **Attention:** Due to the operation the device might be contaminated by harmful or dangerous substances, clean or decontaminate prior to maintenance.
- Before starting **maintenance** vent the system, isolate the device from the vacuum system.

Ensure that maintenance is done only by suitably trained and supervised technicians.

Interior components of the device can only be repaired at the factory.

NOTICE

In order to comply with law (occupational, health and safety regulations, safety at work law and regulations for environmental protection) vacuum pumps, components and measuring instruments returned to the manufacturer can be repaired only when certain procedures (see section “**Notes on return to the factory**”) are followed.

Technical data

Technical data of display equipment

Display equipment	DCP 3000
Display	illuminated LCD graphic display
Pressure units/scale	mbar, Torr or hPa
Ambient temperature range (operation)	+ 10°C to + 40°C
Ambient temperature range (storage)	- 10°C to + 70°C
Max. permitted relative ambient moisture at operation (no condensation)	30% to 85%
Mains supply (see rating plate)	24 V= (+/- 6V)
Maximum permitted current for valves (connected components)	4 A
Maximum power draw	3.4 W (140 mA at 24 V=)
Degree of protection IEC 529	
Instrument front	IP 42
Interface	RS 232C
Mass (without mains adapter)	0,44 kg
Dimensions L x W x H	138 mm x 124 mm x 115 mm

Technical data of pressure transducer

Pressure transducer	VSK 3000
Measuring range	1080 mbar - 0.1 mbar
Measurement uncertainty (absolute) after adjustment	+/- 1 mbar
Resolution	0.1 mbar
Maximum permissible pressure	1.5 bar absolute (1125 Torr)
Measuring principle	capacitive, independent of gas type
Temperature coefficient	< 0.07 mbar / K
Max. permitted temperature of gaseous media	maximum 80°C for short periods
Ambient temperature range (operation)	+10°C to +40°C
Ambient temperature range (storage)	-10°C to +70°C
Permissible relative atmospheric moisture during operation	30 - 85 %, no condensation
Supply voltage (via VACUU•BUS)	6-30 V= / 5 mA
Degree of protection according to IEC 529	IP 54
Weight	0.18 kg
Housing dimensions diameter length with vacuum connection	60 mm 60 mm (small flange) 95 mm (hose nozzle) 63 mm (hose connection)
Vacuum connection of gauge head	small flange NW 16 or hose nozzle NW 6/10 or hose connection NW 8/10
Cable length	approx. 2.0 m
Communication	VACUU•BUS

We reserve the right for technical modification without prior notice!

Wetted parts VSK 3000

Components	Wetted parts
Sealing at the pressure transducer	chemically resistant fluoroelastomer
Gauge head housing	PPS glass fibre reinforced
Pressure transducer	aluminium oxide ceramic
Hose nozzle	PP
Small flange (only for non corrosive applications)	aluminium / NBR

We reserve the right for technical modification without prior notice!

Technical data of power supply

Power supply (wall plug)	
Input voltage incl. tolerance	90-264 V~, 47-63 Hz
Maximum current draw	0.8 A
Ambient temperature range (operation)	0°C to +40°C
Ambient temperature range (storage)	-20°C to +85°C
Output voltage	24 V=, short-circuit proof
Maximum output current	1.25 A
Mains connection	exchangeable plug Europe / UK / USA / AUS
Dimensions	108 mm x 58 mm x 34 mm
Weight	0.24 kg

Accessories

Pressure transducer VSK 3000, capacitive Al ₂ O ₃ sensor 1080-0.1 mbar	63 66 57
Venting valve VBM-B / KF 16 or hose nozzle 6/10mm, 24 V=	67 42 17
Y-type adapter VACUU•BUS	63 66 56
Extension cable VACUU•BUS, 2m	61 25 52
Cable RS 232C, 9-pole, Sub-D	63 78 37

➔ The VACUUBRAND gauge DCP 3000 can only be operated with components compatible to the VACUUBRAND **VACUU•BUS system**, see accessories.

Conversion of a VACUUBRAND valve with diode plug to a VACUUBRAND valve with VACUU•BUS plug:

VACUUBRAND valve with diode plug	Conversion kit valve cable with VACUU•BUS plug
Venting valve VBM, 24 V= (66 68 17)	61 25 54

Use and operation

Assembling the country specific mains plug

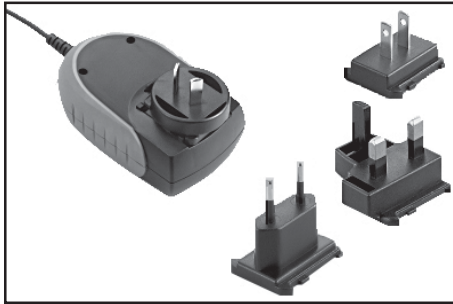

- ☞ The wall power supply is delivered with mains plugs for Europe, UK, USA and Australia.
- ☞ To replace the mains plug press the locking key and remove mains plug.
- ☞ Assemble the suitable mains plug to the power supply and lock.

When switching on the DCP 3000 for the very first time, a menu to select the language of the device is displayed. Select the desired language ("Deutsch", "English", "Français") by turning the selection knob and press to confirm. Then select the pressure unit ("mbar", "Torr" or "hPa") in the same way.

It is possible to access the language selection menu at any time by switching on the device while keeping the selection knob pressed.

The connected components (valves, external sensor) are identified and configured automatically.

Display and symbols

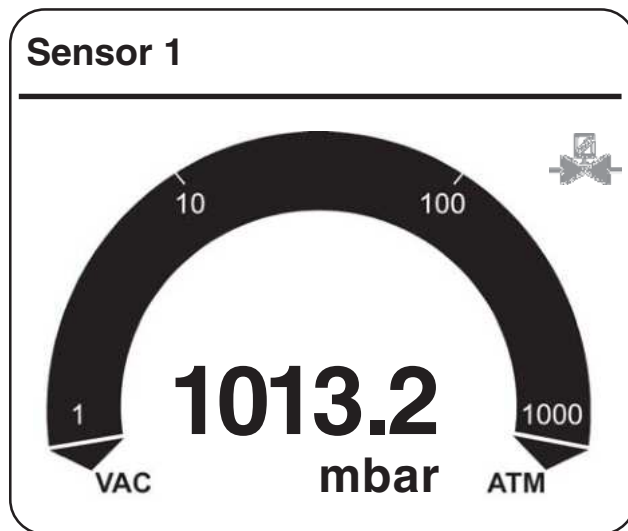

Sensor 1 active sensor



Venting valve switched on (if connected)



Warning notice (if necessary in combination with other symbols), flashing

1013.2 actual absolute pressure at the pressure transducer

mbar
Torr
hPa

preselected pressure unit

Keys

Venting: Only after connection of an external venting valve

- Short pressing vents short-time, control runs on.
- Pressing longer than 2 seconds vents the system to atmospheric pressure.

on/off switch

Selection knob

- Press to reach the set-up menu of the function
- Turn to reach the parameter set-up
- Press to reach the set value
- Turn to change the set value
- Press to confirm and to reach further parameters or to exit the set-up menu

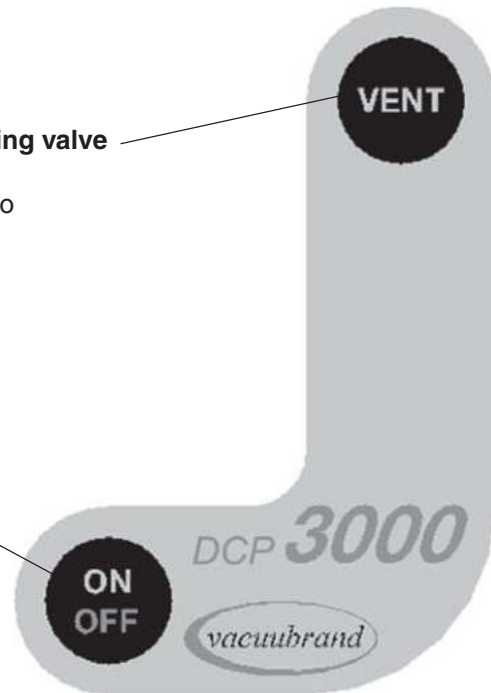

Rear side DCP 3000

sockets for connection of external pressure transducer and/or venting valve

connection power supply

serial interface RS 232 C

rating plate

stand foot, removable, also for mounting in a rod clamp



Attention: Do not cant when assembling or removing plug connections! Comply with correct positioning of the plug. To connect further components use Y-adapters and extension cables VACUU•BUS. When connecting an external pressure transducer it is used automatically. Further information on how to use several sensors on request.

Changing the vacuum connector

Installing the hose nozzle

Screw off small flange. Slip hose nozzle with clamping ring onto the vacuum connection and fixate with union nut.

Installing the PTFE-tubing connection (PTFE-tubing ID: 8mm, OD: 10mm):

Screw off small flange. Remove clamping ring and union nut from hose nozzle and slip both onto PTFE-tubing. Slip PTFE-tubing onto the vacuum connection and fixate with union nut.

Notes on operation

Operating mode DCP 3000

The DCP 3000 is equipped with a ceramic pressure transducer to measure the absolute pressure according to the capacitive principle of measurement independent of the gas type.

The pressure value is displayed with a resolution of 0.1 mbar in the whole pressure range.

VACUU•BUS

The read out of the pressure transducer occurs via VACUU•BUS line by the vacuum gauge DCP 3000 using VACUU•BUS protocol. The maximum cable length inside a building is 30m (extension cable VACUU•BUS 2m, cat. no: 61 25 52).

Don't use more than one DCP 3000 within a VACUU•BUS system. More than one DCP 3000 within the same VACUU•BUS system will interfere with each other and cause error messages of the connected components.

Prior to use

- ➔ Connect gauge head with connecting cable to a socket at the rear side of the equipment.
- ➔ Connect the gauge head to the vacuum chamber via the small flange connection, the hose nozzle or PTFE tubing. Avoid contamination (oil/oil mist) of the gauge head when generating the vacuum with an oil-filled vacuum pump.
- ⚠ Do not mount the gauge head directly at the pump. The diameter of the pipelines should be as large as possible.
- ➔ Switch on the equipment.

Automatic detection of connected components

When switching on the device the actual configuration of the connected components is checked.

Connected components (valves, sensors) are **automatically detected**, used and supervised until the device is switched off. Switching off/on the device leads to reconfiguration if necessary.

The configuration menu is stored in the device, see "Configuration" with specific settings adapted **automatically** to the connected components.

Depending on the connected components (valves, sensors) some menu items are not active!



Max. permitted pressure at the pressure transducer: 1.5 bar (absolute).

- ⚠ The display flashes at a pressure higher than approximately 1080 mbar. **Immediate pressure release. Risk of bursting!**
- ⚠ Inside a vacuum system where evaporation occurs (e.g. rotary evaporator) the vacuum is not uniform, e.g. a condenser acts as pump or the vacuum in the pipeline is lower than in the system. Therefore choose the position where to connect the gauge head carefully.
- ⚠ Condensate and deposits at the gauge head falsify the measurement result.
- ⚠ If residues occur or when working with aggressive or condensable substances, install a gas washing bottle in front of the pressure gauge head.
- ⚠ **Position the gauge head in such a way that condensate can not flow into it.**
- ⚠ If necessary, clean the gauge head.

Menu

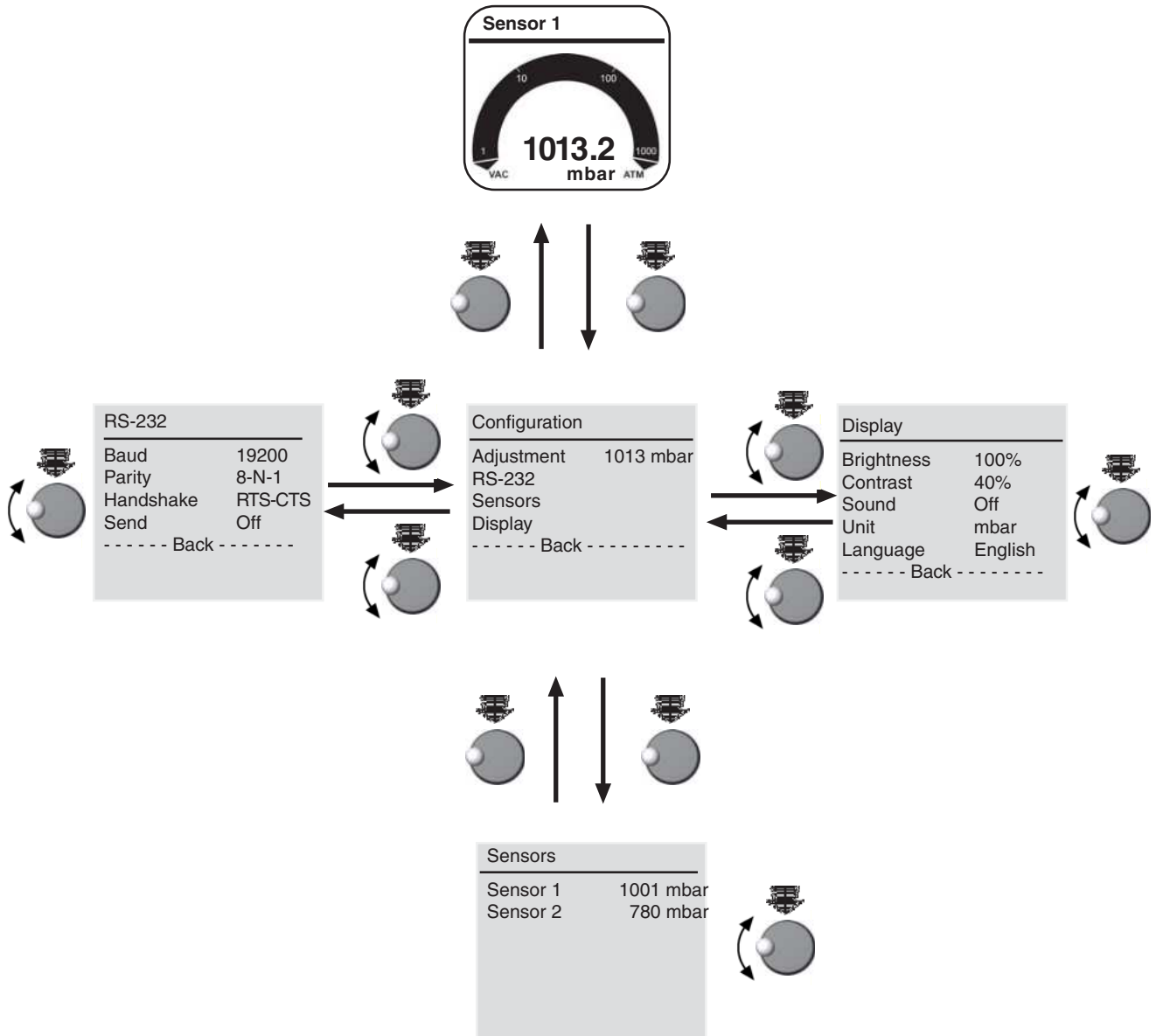

Configuration

In the menu "Configuration" the device parameters are preselected.

Preselections

- ☞ Select the parameters via the selection knob.
- ☞ The device is switched on.
- ➔ Press the selection knob.
- ➔ Turn the selection knob to choose a menu and confirm by pressing the selection knob.

"Configuration"

Settings for

- Adjustment (of the pressure transducer)
- RS-232 (serial interface)
- Sensors (configuration and switching between several sensors)
- Display (brightness and contrast of the display, language, sound,.....)

☞ **Adjustment:** Adjustment of the pressure transducer under vacuum and/or at atmospheric pressure, see section "Adjustment".

Adjustment at atmospheric pressure is carried out between 1060 - 700 mbar (absolute) and under vacuum between 0 - 20 mbar (absolute).

☞ **RS-232:** Configuration of the interface, setting of parameters and commands, see section "Interface parameters".

Baud rate is selectable on 19200, 9600, 4800 or 2400, parity on "8-N-1", "7-O-1" or "7-E-1", Handshake on "no", "Xon-Xoff" or "RTS-CTS" and remote on "On" or "Off".

Automatic sending of pressure values "off" (only on demand) or in a time interval of 1 360 seconds. To switch off automatic sending select "off" or stop via serial interface.

☞ **Sensors:** Selection of the gauge head to be controlled (maximum 4 sensors).

☞ **Display:** Selection of the device parameters

"Brightness" between 0 - 100% and "Contrast" between 0 - 100% of the display

"Sound" "On" or "Off" in case of faults

"Units" (pressure units) "mbar", "hPa" or "Torr"

"Language" of the display "Deutsch", "English" or "Français".

The screen-shot shows the factory-set values.

Configuration	
Adjustment	1013 mbar
RS-232	
Sensors	
Display	
----- Graphic -----	
----- Back -----	

Interface parameters

The device DCP 3000 is equipped with a serial interface (RS 232C, nine-pole Sub-D-plug).

- ☛ Plug-in or remove the cable (cable RS 232C) from the interface only if the equipment is switched off.
- ☛ The interface is **not** electrically isolated from the measuring circuit.
- ☛ For optimal electromagnetic compatibility assemble an interface filter (cat. no.: 63 82 35).

Setting of the interface

Set the interface parameters directly at the device.

The factory set values are underlined.

Edit and confirm the interface parameters in the function "Configuration" in the menu "RS-232" using the selection knob.

- ➔ Baud: 2400, 4800, 9600 or 19200
 - ➔ Parity: 8-N-1, 7-O-1 or 7-E-1
 - ➔ Handshake: Off, Xon-Xoff or RTS-CTS
 - ➔ Sending: Off or 1.....360 s
-
- ➔ Maximum 20 commands per second are possible.
 - ➔ The commands have to be written in capital letters.
 - ➔ Command and parameter have to be separated by a blank.
 - ➔ The string is terminated with <CR> or <CR><LF>.
 - ➔ The response of the device is always terminated with <CR><LF>.
 - ➔ Numerical values and parameters can be written without leading zeros.
 - ➔ The response of the device is always with leading zeros.

Read commands

Function	Command Response	Description
actual pressure	IN_PV_1 XXXX.X mbar/Torr/hPa	unit according to preselections
pressure	IN_PV_Sx XXXX.X mbar/Torr/hPa	pressure of sensor x
	IN_PV_X XXXX.X XXXX.X ...mbar	pressure of all connected sensors

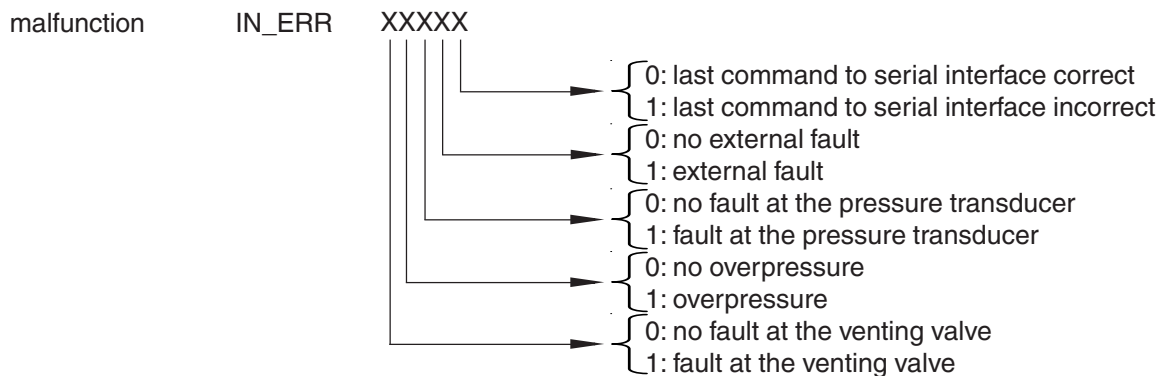
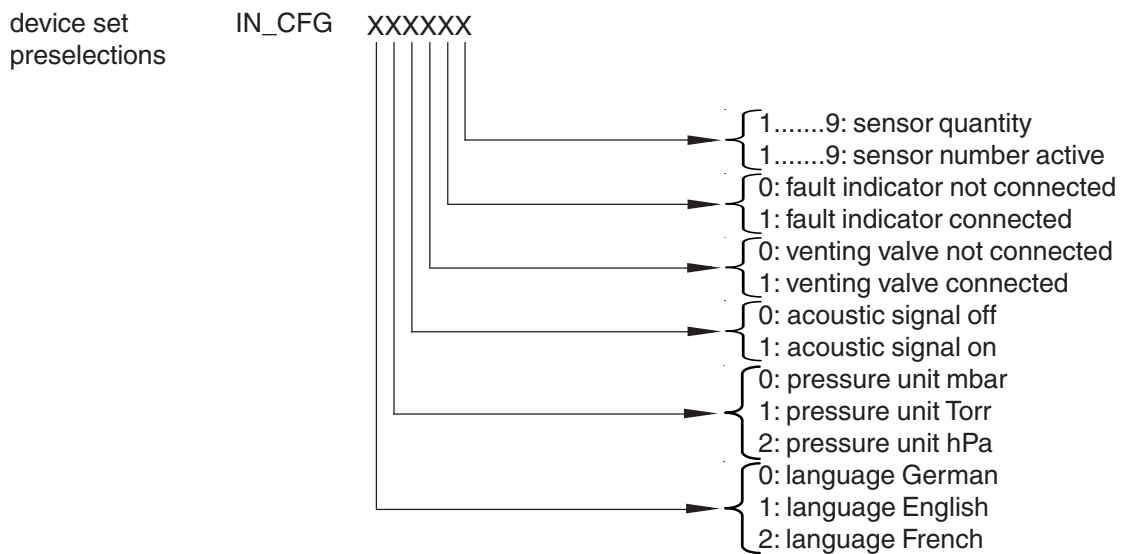

IN_VER	DCP 3000 Vx.xx	software version
IN_SP_1	XX:XX	time interval for sending mm:ss

Write commands

Function	Command	Parameter	Description
time	OUT_SP_1	XX:XX	time interval for automatic sending of all pressure values mm:ss sss
alternative		XXX	
	OUT_VENT	X	{ <ul style="list-style-type: none"> 0: venting valve closed 1: venting valve open 2: venting until atmospheric pressure
	OUT_SENSOR	X	1-9 external sensors (if connected)

The single abbreviations of a command are separated by underscores (ASCII 5FH).
The string is terminated with <CR><LF> (ASCII 0DH, ASCII 0AH).

Connector assignment

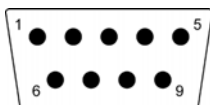

2: RxD
3: TxD
4: DTR

5: Mass
7: RTS
8: CTS
9: +5V (Bluetooth)

Troubleshooting

Fault	Possible cause	Remedy
<input type="checkbox"/> No display.	<ul style="list-style-type: none"> ➔ Mains not plugged in, no power available? ➔ Other causes (device defective)? 	<ul style="list-style-type: none"> ☞ Insert mains plug, check mains fuses. ☞ Return the device to the factory for repair.
<input type="checkbox"/> Malfunction indicator gauge head (warning triangle is flashing).	<ul style="list-style-type: none"> ➔ Gauge head not connected? ➔ Gauge head or connecting cable defective? 	<ul style="list-style-type: none"> ☞ Connect gauge head. ☞ Replace gauge head or connecting cable if necessary.
<input type="checkbox"/> The pressure reading is too high in the low pressure range.	<ul style="list-style-type: none"> ➔ Gauge head contaminated? ➔ Adjustment is wrong? 	<ul style="list-style-type: none"> ☞ Clean gauge head and readjust. ☞ Readjust gauge head.
<input type="checkbox"/> The pressure reading is too low at atmospheric pressure.	<ul style="list-style-type: none"> ➔ Misadjusted gauge head? 	<ul style="list-style-type: none"> ☞ Readjust gauge head.
<input type="checkbox"/> Displayed pressure is fluctuating.	<ul style="list-style-type: none"> ➔ Pressure fluctuation due to the set-up of the vacuum system? ➔ Plug of the cable to the gauge head not correctly plugged in? ➔ Position of the gauge head has been changed (e. g. from horizontal to vertical)? Fluctuation of the displayed pressure in the range of 0.2 - 0.4 mbar? 	<ul style="list-style-type: none"> ☞ No measuring fault, check and change set-up of the vacuum system if necessary. ☞ Plug in correctly at DCP 3000. ☞ Readjust if necessary (if exact pressure indication is required).



Instructions for repair with directions for repair and spare parts list is available on request.

☞ The instructions are for trained service people.

Cleaning the pressure transducer

The gauge itself is maintenance free.

Contamination of the gauge head or deposits will influence the accuracy of measurement.

Attention: Never use a spiky or sharp-edged tool to clean the pressure transducer.

Clean a contaminated pressure transducer as follows:

- ➔ Fill the measurement chamber with a solvent (e. g. benzene) and allow sufficient cleaning time. Observe all regulations concerning usage and disposal of solvents!
- ➔ Drain the solvent and dispose of in accordance with regulations, repeat cleaning if necessary.
- ➔ Rinse the gauge head chamber several times with alcohol in order to remove all solvent residues.
- ➔ Allow the pressure transducer to dry.
- ➔ Readjust the pressure transducer if necessary.

Calibration in the factory

Control of measuring equipment

The **VACUUBRAND DKD calibration laboratory** is accredited by the Physikalisch-Technische Bundesanstalt (PTB; German national institute for science and technology and the highest technical authority of the Federal Republic of Germany for the field of meteorology and certain sectors of safety engineering) for the measurable variable **pressure in the pressure range from 10^{-3} mbar to 1000 mbar** in accordance with the general criteria for the operation of testing laboratories defined in the standard EN ISO/IEC 17025:2000.

Calibration in the VACUUBRAND calibration laboratory:

- To meet the requirements of the DIN ISO 9000ff and 10012 series of standards regarding the calibration of inspection, measuring and test equipment at specified intervals.
- To document that the vacuum gauges calibrated are traceable to national standards of the PTB.

DKD calibration display unit with gauge head VSK 3000 90 02 15

Readjustment



The vacuum gauge was adjusted using factory standards, which are traceable through regular calibration in an accredited laboratory (German Calibration service) to the German national pressure standard. Depending on the process and/or accuracy requirements, check the adjustment and readjust if necessary. For readjustment, the device has to be adjusted both at atmospheric pressure as well as under vacuum but only if the reference pressures are certainly known.

The adjustment mode can be activated only if the process control is inactive. Press key "START/STOP" if necessary.

Adjustment at atmospheric pressure

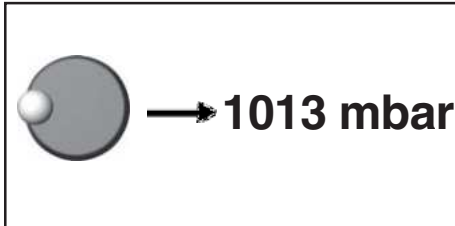

An adjustment at atmospheric pressure is only possible if the pressure is higher than 700 mbar.

Ventilate the device and/or the vacuum system. Make sure that the vacuum connection at the device is at atmospheric pressure.

- ➔ In function "Configuration" select program "Adjustment" at the device.
- ➔ Use the selection knob to adjust the reading to the actual atmospheric pressure.
- ➔ Press the selection knob to confirm.

Note: To determine the actual atmospheric pressure, use an accurate barometer or get accurate reading from the weather service, the next airport.....(take into account the difference in altitude between e. g. airport and laboratory).

Adjustment under vacuum



An adjustment under vacuum is only possible if the pressure is lower than 20 mbar.

Evacuate the gauge head to a pressure < 0.1 mbar (e. g. by applying a good two-stage rotary vane pump).

- ➔ In function "Configuration" select program "Adjustment" at the device.
- ☞ The reading is automatically adjusted to "zero".
- ➔ Press the selection knob to confirm.

Note: Adjustment under vacuum with an actual pressure higher than 0.1 mbar reduces the accuracy of the measurement. If the pressure is significantly higher than 0.1 mbar, adjustment to a reference pressure is recommended.

Adjustment at a reference pressure

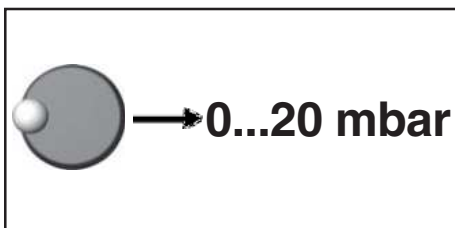

Instead of adjustment under vacuum to a pressure < 0.1 mbar, adjustment to a precisely known reference pressure within the range of 0 20 mbar is possible. Evacuate the pressure transducer to a pressure within 0 20 mbar

- ➔ In function "Configuration" select program "Adjustment" at the device.
- ☞ The reading is automatically adjusted to "zero".
- ➔ Use the selection knob to adjust the display to the reference pressure at the vacuum line within the range of 0 20 mbar.
- ➔ Press the selection knob to confirm.

Note: The accuracy of the value of the reference pressure will directly affect the accuracy of the adjustment. If the nominal ultimate vacuum of a diaphragm pump is used as reference vacuum, the accuracy of the device might be doubtful. The diaphragm pump may not achieve the specified value (due to condensate, poor condition, failure of valves or diaphragm).

Notes on return to the factory

Repair - return - DKD calibration

NOTICE

Safety and health of our staff, laws and regulations regarding the handling of dangerous goods, occupational health and safety regulations and regulations regarding safe disposal of waste require that for all pumps and other products the “**Health and safety clearance form**“ must be send to our office duly completed and signed before any equipment is dispatched to our premises.

Fax or post a completed copy of the health and safety clearance form to us in advance. The declaration must arrive before the equipment. Enclose a second completed copy with the product. If the equipment is contaminated you must notify the carrier.

No repair / DKD calibration is possible unless the correctly completed form is returned. Inevitably, there will be a delay in processing the equipment if information is missing or if this procedure is not complied with.

CAUTION

If the product has come in contact with chemicals, radioactive substances or other substances dangerous to health or environment, the product must be decontaminated **prior to sending it back to the factory.**

- Return the product to us **disassembled and cleaned** and accompanied by a certificate verifying decontamination or
- Contact an industrial cleaning and **decontamination service** directly or
- Authorize us to send the product to an industrial cleaning facility **at your expense.**

To expedite repair and to reduce costs, please enclose a detailed description of the problem and the product’s operating conditions with every product returned for repair. We submit **quotations** only on request and always at the customer’s expense. If an order is given, the costs incurred are offset from the costs for repair or from the purchase price, if the customer prefers to buy a new product instead of repairing the defective one.

- **If you do not wish a repair on the basis of our quotation, the equipment might be returned to you disassembled and at your charge!**

In many cases, the **components must be cleaned in the factory** prior to repair. For cleaning we use an environmentally responsible water based process. Unfortunately the combined attack of elevated temperature, cleaning agent, ultrasonic treatment and mechanical stress (from pressurised water) may result in damage to the paint. Please mark in the health and safety clearance form if you wish a **repaint at your expense** just in case such a damage should occur.

We also replace parts due to optical aspects upon your request.

NOTICE

Before returning the equipment ensure that (if applicable):

- Equipment has been cleaned and/or decontaminated.
- All inlet and outlet ports have been sealed.
- Equipment has been properly packed, if necessary, please order an original packaging (costs will be charged), marked as appropriate and the carrier has been notified.
- Ensure that the completed health and safety declaration is enclosed.

We hope for your understanding for these measures, which are beyond our control.

Scrapping and waste disposal:

Dispose of the equipment and any components removed from it safely in accordance with all local and national safety and environmental requirements. Particular care must be taken with components and waste oil which have been contaminated with dangerous substances from the process. Do not incinerate fluoroelastomer seals and “O” rings.

- You may authorize us to dispose of the equipment **at your expense.**

Health and safety clearance form

Declaration concerning safety, potential hazards and safe disposal of waste, e. g. used oil.

Safety and health of our staff, laws and regulations regarding the handling of dangerous goods, occupational health and safety regulations, safety at work laws and regulations regarding safe disposal of waste, e. g. waste oil, require that for all pumps and other products this form must be sent to our office duly completed and signed before any equipment is dispatched to our premises. **Products will not be accepted for any procedure and handling and repair / DKD calibration will not start before we have received this declaration.**

- a) Fax or post a **completed copy of this form** to us in advance. The declaration must arrive before the equipment. **Enclose a second, completed copy with the product.** If the product is contaminated you must notify the carrier (GGVE, GGVS, RID, ADR).
- b) Inevitably, the repair process will be delayed considerably, if this information is missing or this procedure is not complied with. We hope for your understanding for these measures which are beyond our control and that you will assist us in expediting the repair procedure.
- c) **Make sure that you know all about the substances which have been in contact with the equipment and that all questions have been answered correctly and in detail.**

1. Product (Model):	5. Way of transport / carrier: Day of dispatch to VACUUBRAND:
2. Serial No.:	
3. List of substances in contact with the equipment or reaction products:	
3.1 Chemical/substance name, chemical symbol:	
a)	If the paint is damaged, we wish a repaint or a replacement of parts due to optical aspects at our expense (see "Notes on return to the factory"): <input type="checkbox"/> yes <input type="checkbox"/> no
b)	
c)	
d)	
3.2 Important informations and precautions, e. g. danger classification:	We declare that the following measures - where applicable - have been taken:
a)	- The oil has been drained from the product. Important: Dispose of according to national regulations.
b)	- The interior of the product has been cleaned.
c)	- All inlet and outlet ports of the product have been sealed.
d)	- The product has been properly packed, if necessary, please order an original packaging (costs will be charged) and marked as appropriate.
4. Declaration (please mark as applicable):	- The carrier has been informed about the hazardous nature of the goods (if applicable).
<input type="checkbox"/> 4.1 for non dangerous goods:	We assure VACUUBRAND that we accept liability for any damage caused by providing incomplete or incorrect information and that we shall indemnify VACUUBRAND from any claims as regards damages from third parties.
We assure for the returned product that	We are aware that as expressed in § 823 BGB (Public Law Code of Germany) we are directly liable for injuries or damages suffered by third parties, particularly VACUUBRAND employees occupied with handling/repairing the product.
- neither toxic, corrosive, biologically active, explosive, radioactive nor contamination dangerous in any way has occurred.	Signature:
- the product is free of dangerous substances.	Name (print):
- the oil or residues of pumped media have been drained.	Job title (print):
<input type="checkbox"/> 4.2 for dangerous goods:	Company's seal:
We assure for the returned product that	Date:
- all substances, toxic, corrosive, biologically active, explosive, radioactive or dangerous in any way which have pumped or been in contact with the product are listed in 3.1, that the information is complete and that we have not withheld any information.	
- the product, in accordance with regulations, has been	
<input type="checkbox"/> cleaned <input type="checkbox"/> decontaminated <input type="checkbox"/> sterilized.	

VACUUBRAND GMBH + CO KG
-Technology for Vacuum Systems-

© 2001 VACUUBRAND GMBH + CO KG Printed in Germany

Alfred-Zippe-Str. 4 - 97877 Wertheim
Tel.: +49 9342 808-0 - Fax: +49 9342 808-450
E-Mail: info@vacuubrand.de
Web: www.vacuubrand.com





**Konformitätserklärung
Declaration of conformity
Déclaration de conformité**

Vakuummessgerät / Vacuum gauge / Vacuomètre

DCP 3000 (68 31 70) 100-230V

Hiermit erklären wir, dass das oben bezeichnete Gerät in Konzeption und Bauart sowie in der von uns in Verkehr gebrachten Ausführung den grundlegenden Anforderungen der zutreffenden, aufgeführten EU-Richtlinien entspricht. Bei einer mit uns nicht abgestimmten Änderung an dem Gerät verliert diese Erklärung ihre Gültigkeit.

We herewith declare that the product designated above is in compliance with the basic requirements of the applicable EC-directives stated below with regard to design, type and model sold by us. This certificate ceases to be valid if the product is modified without the agreement of the manufacturer.

Par la présente, nous déclarons que le dispositif désigné ci-dessus est conforme aux prescriptions de base des directives EU applicables et indiqués en ci que concerne conception, dessin et modèle vendu par nous-mêmes. Cette déclaration cesse d'être valable si des modifications sont apportées au dispositif sans notre autorisation préalable.

Niederspannungsrichtlinie / Low-Voltage Directive / Directive Basse Tension
2006/95/EG

Richtlinie Elektromagnetische Verträglichkeit / Electromagnetic Compatibility Directive / Directive
Compatibilité Electromagnétique
2004/108/EG

Angewandte Harmonisierte Normen / Harmonized Standards applied / Normes Harmonisées utilisées
DIN EN 61010-1, DIN EN 61326

Managementsysteme / Management systems / Systèmes de Management
EN ISO 9001, EN ISO 14001 (1997-2006)

Wertheim, 16.01.2008

Ort, Datum / place, date / lieu, date

(Dr. F. Gitmans)

Geschäftsführer / Managing director / Gérant

ppa.

(Dr. J. Dirscherl)

Technischer Leiter / Technical Director / Directeur technique

VACUUBRAND GMBH + CO KG

-Vakuumentchnik im System-
-Technology for Vacuum Systems-
-Technologie pour système à vide-

Alfred-Zippe-Str. 4 - 97877 Wertheim

Tel.: +49 9342 808-0 - Fax: +49 9342 808-450

E-Mail: info@vacuubrand.de

Web: www.vacuubrand.com

Disclaimer: Our technical literature is only intended to inform our customer. The validity of general empirical values and results obtained under test conditions for specific applications depend on a number of factors beyond our control. It is therefore strictly the users' responsibility to very carefully check the validity of application to their specific requirements. No claims arising from the information provided in this literature will, consequently, be entertained.

VACUUBRAND GMBH + CO KG
-Technology for Vacuum Systems-

© 2008 VACUUBRAND GMBH + CO KG Printed in Germany

Alfred-Zippe-Str. 4 - 97877 Wertheim
Tel.: +49 9342 808-0 - Fax: +49 9342 808-450
E-Mail: info@vacuubrand.de
Web: www.vacuubrand.com

